

	Page
The Inception	3
What is Load Sensing?	4
How Load Sensing Works	5
Advantages of Load Sensing	14
Development and Testing	25
Comparison of Systems	26
Applications	27
Future of Load Sensing Systems	27

In the late 1960's some young engineers pondered the advantages and disadvantages of hydraulic systems. The open center hydraulic system, using a fixed displacement gear pump, provides a fixed flow of oil. System pressure is dictated by the resistance to flow in the hydraulic system. A high pressure relief valve is necessary to control the maximum system pressure; when the system reaches maximum pressure, full pump flow is bypassed through the relief valve, consuming excess horsepower and generating excessive heat in the system.

The closed center system, on the other hand, offers the advantage of variable flow from zero to full flow and eliminates the need for the system relief valve. Maximum pressure is controlled by the pump compensator that destrokes the pump and cuts off the flow to the system when the hydraulic system stalls out due to an overload condition. The pump will standby at high pressure, maintaining the maximum pressure, until the load is overcome or the hydraulic system is placed back into its standby condition. The disadvantage of the closed center system is that the pump strives to maintain maximum high pressure under all conditions. There are system conditions where high flow rates are

desired, but only low working pressure is required. The closed center system takes high pressure drops under these conditions and generates excessive heat during this energy wasting process.

The engineers thought there must be a better way of combining the advantages of both systems. The ideal system would provide only the flow required, at the pressure required, to operate the hydraulic system. Variable pressure and variable flow are desirable, yet neither the open center or closed center system offer these features. The solution required the development of a new pump that could deliver variable flow and variable pressure as dictated by the hydraulic system. Obviously, a variable piston pump was an ideal basic pump to start with but, how do you make it respond to both variables?

One of the engineers on this project developed a new pump compensator that sensed both the pressure and flow requirements of the system and caused the piston pump to properly react to both variables. The load sensing pump was born! Technically, it is called a Pressure-Flow Compensated Variable Volume Piston Pump.

What is Load Sensing?

Very simply stated, it is a hydraulic system that senses and provides only the pressure and flow required by the hydraulic system.

The components required to accomplish the characteristics of the load sensing system are: A variable volume piston pump, that has a compensator that will allow the pump to standby at low pressure (200 PSI) when the system is not being actuated. It will sense the flow requirements of the system when it is being actuated and provide a variable flow rate as the flow demands of the hydraulic system are varied. The pump must also sense and respond to the varying pressure requirements of the hydraulic system. Most hydraulic systems do not operate at constant pressure. The hydraulic pressure will vary as the load on the hydraulic system changes.

A control valve, with special sensor passages and checks, is also required

to get the full benefit of the load sensing system. When the hydraulic system is not being operated, and is in the standby mode, the control valve must cut off the pressure signal from the actuating cylinder (or motor) to the pump. This causes the pump to automatically go into low pressure standby when the system is not being operated. When the control valve is actuated, the control valve will pick up the pressure requirement from the actuating cylinder (or motor) and send that pressure signal back to the pump where the pump starts to respond to the system pressure. The flow requirement of the system is dictated by the movement of the spool. The system flow requirement is sent back to the pump, through the signal line, from the control valve. This combination of a load sensing pump and load sensing control valve allows the total system to provide only the flow and pressure required by the load sensing system.

Color Code

Blue	Return/Intake – Any oil in the circuit not under high pressure. This oil can be pressure free oil from the pump or return oil to the reservoir.
Green	Trapped Oil – Any oil in the circuit not connected to pump flow or return. This oil can be high or low static pressure.
Pink	Low Pressure Standby – Any oil pressurized at the low pressure standby pressure.
Red	Working Pressure – Any oil in the circuit connected to pump flow under working pressure.
Violet	High Pressure Standby – Oil in the system pressurized to the maximum high pressure setting of the compensator.
Yellow	Below Low Pressure Standby – Oil in the pump flow line moments after start-up.

How Load Sensing Works

The Eaton pressure-flow and load sensing hydraulic system has wide application in the fluid power industry and has several distinct advantages when compared to other types of systems.

As the name implies, the system has the ability to monitor system pressure, flow, and load; and adjust its performance accordingly for maximum efficiency. But, before discussing its application and advantages, it is important to know what components make up the system and how they operate.

This is best accomplished by using a simplified system so that the underlying theory and principles of operation can be clearly seen. Here is an axial piston, variable displacement pump, its camplate and camplate control piston.

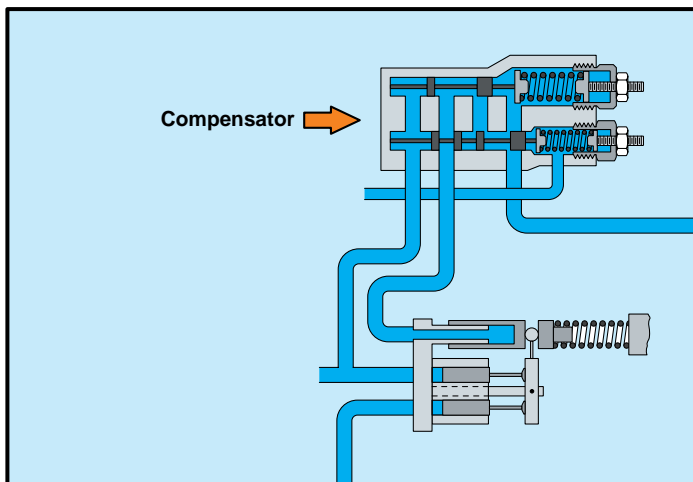
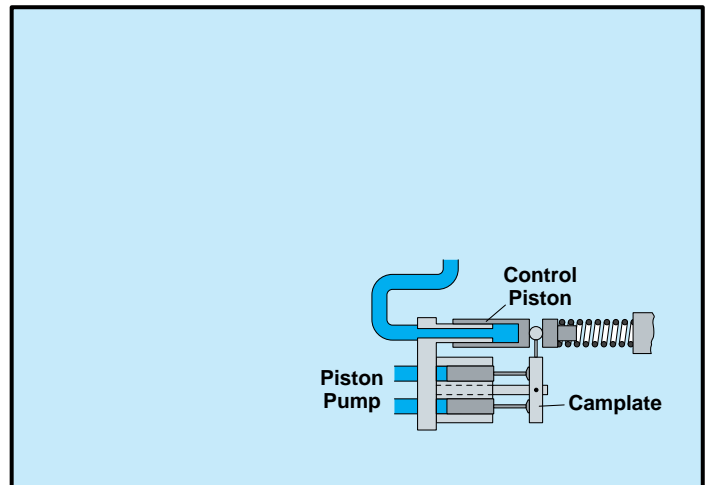

This is the compensator which monitors the system and controls the performance of the pump.

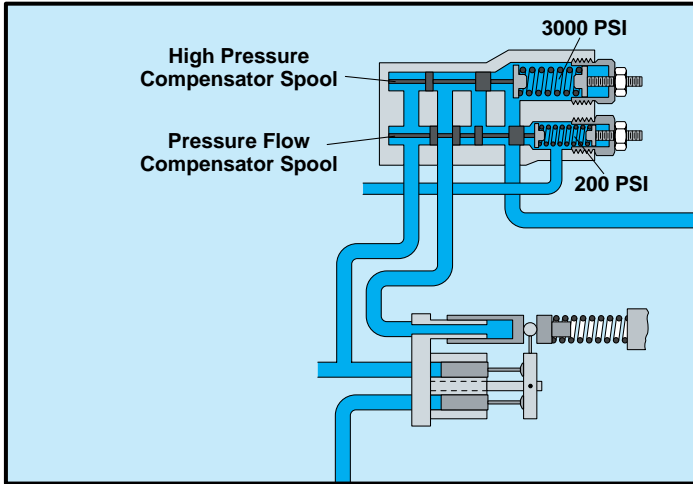

It contains a high pressure compensator spool that works against a 3000 PSI spring; and a pressure-flow compensator spool that works against a 200 PSI spring. The compensator is mounted directly on the pump.

The last two major components are the directional control valve and cylinder. We have shown only one directional control valve and one cylinder to keep the illustration simple. In reality, there can be several valves and cylinders in a system.

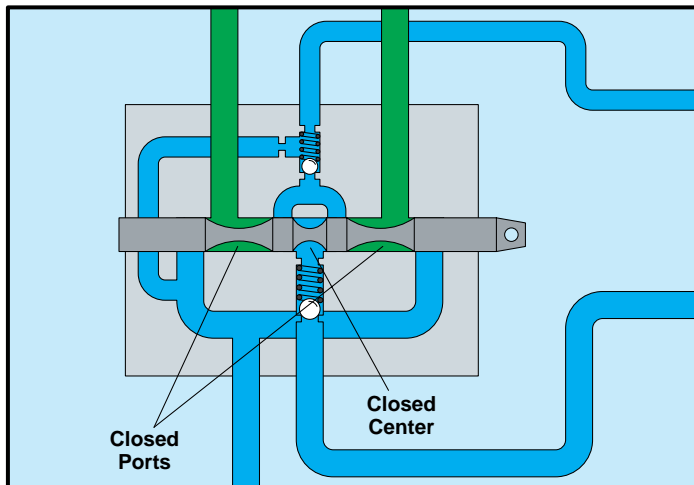
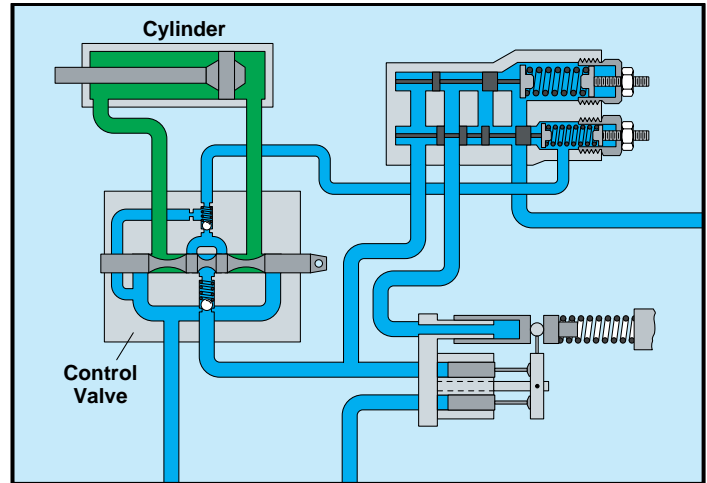

Notice that the directional control valve is the closed center, closed port type. This means that when the spool in the valve is centered, pump flow is blocked at the entrance to the valve and both ports which lead to the cylinder are also blocked

Load Sensing Principle of Operation

The valve contains a lift check which remains closed until the pressure in the pump discharge passage equals the pressure in the cylinder. If not for the lift check, a loaded cylinder would tend to settle when control spool is initially moved.

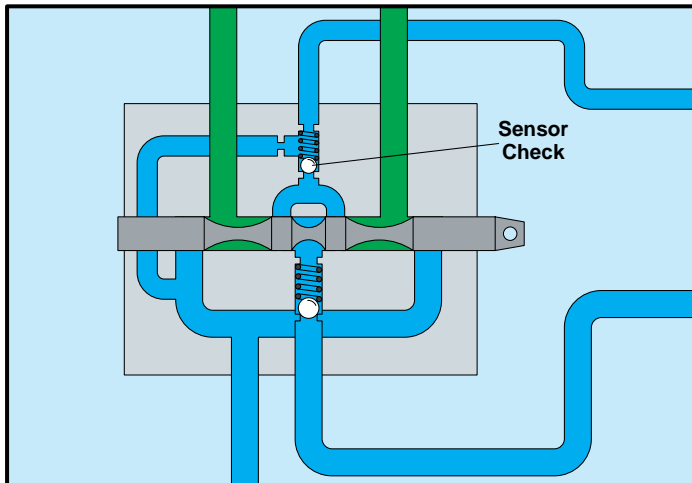
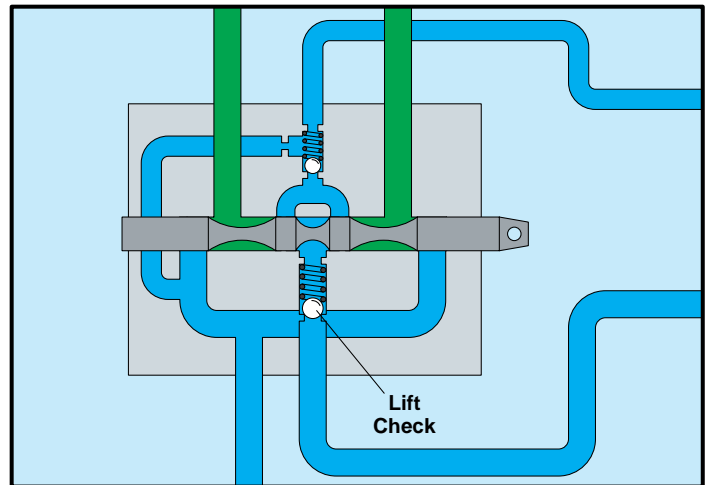

The valve also has a sensor check. When the system has more than one spool, there is a sensor check for each spool. The check allows the compensator to adjust itself to the circuit which calls for the highest pressure.

Assume that the system has been sitting idle and is about to be started. Because there is no pressure in the system, the 200 PSI spring has forced the pressure-flow compensator spool all the way to the left. This provides a direct passage for oil to flow from the camplate control piston to the tank. This drain path is shown in blue.

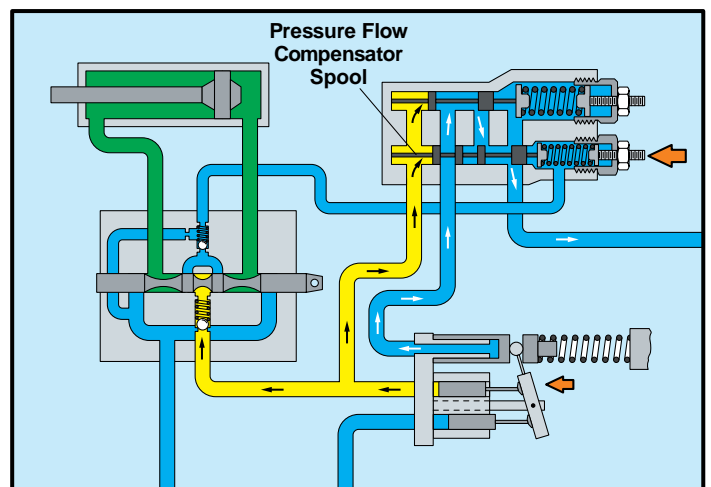

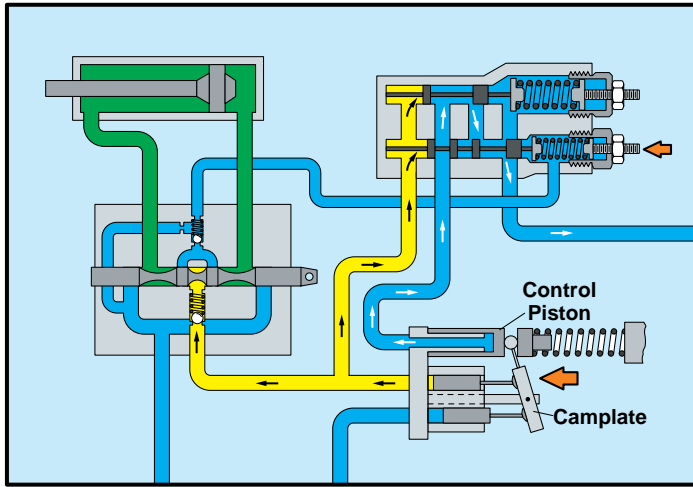

Because there is no oil pressure acting against the control piston, it forces the camplate to move to its maximum angle. In this position, the pump is ready to produce maximum flow.

When the engine or motor is started, pump flow enters the directional control valve, but because it is a closed center type, the flow is blocked.

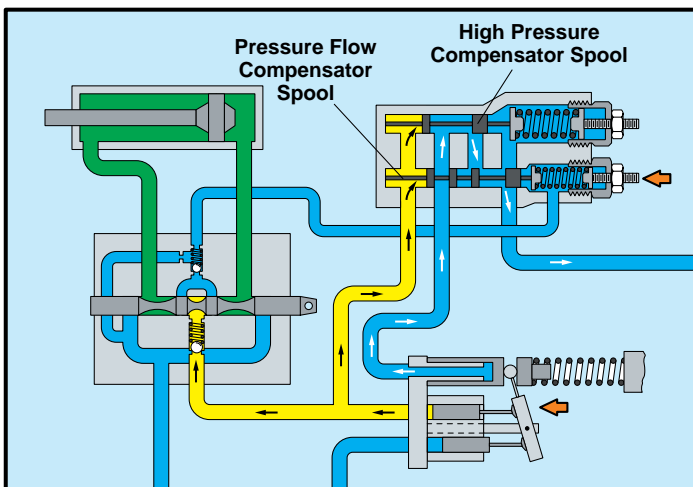
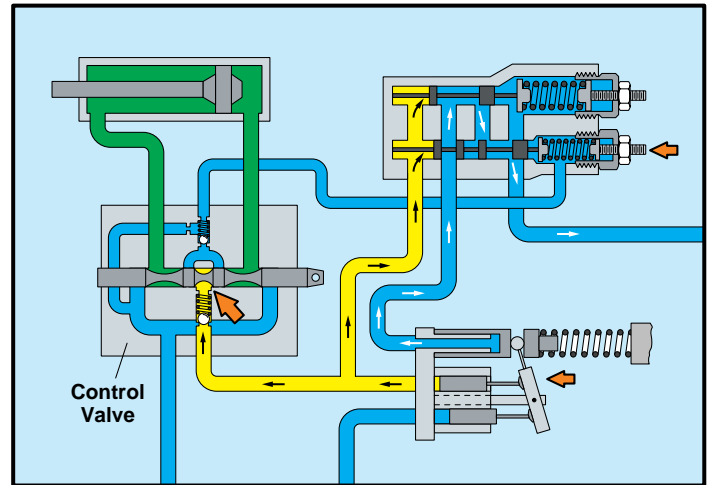

Pump flow also enters the pump compensator. It acts against the left end of the pressure-flow compensator spool and against the left end of the high pressure compensator spool. Remember that all this takes place in a split second.

When the pressure acting against the pressure-flow compensator spool reaches 200 PSI, the spool moves to the right against spring tension. As it moves to the right it uncovers a passage so that the pressure, which has been created in the pump discharge cavity, is channeled to the camplate control piston. The piston moves against its spring and causes the camplate in the pump to stroke back to a near zero displacement angle. This position is called low pressure standby. The pressure-flow compensator spool will modulate back and forth to control the pressure acting on the camplate control piston and ultimately, the flow that the pump will produce. In low pressure standby, the pump will produce only enough flow to make up for internal leakage in the system.

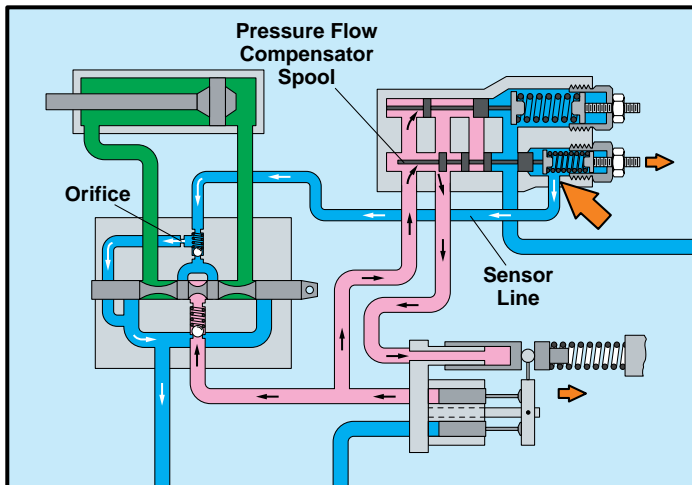
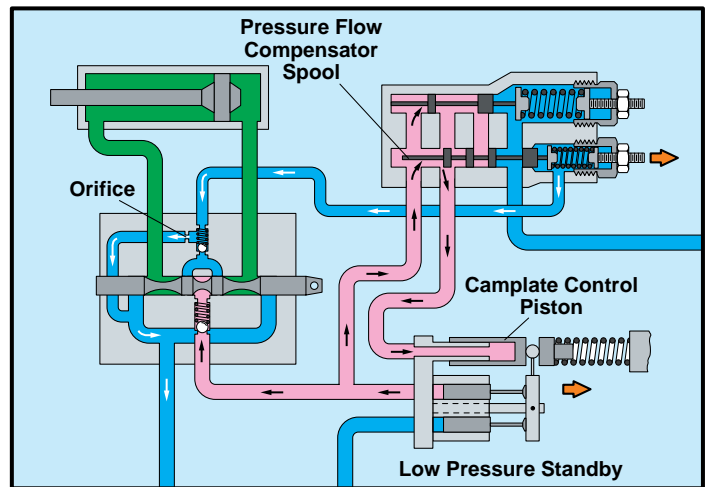

Notice that the spring chamber at the right of the pressure-flow compensator spool is drained of oil. This oil flows from the spring chamber to the directional control valve.

Where it bleeds through a small orifice into the tank cavity.

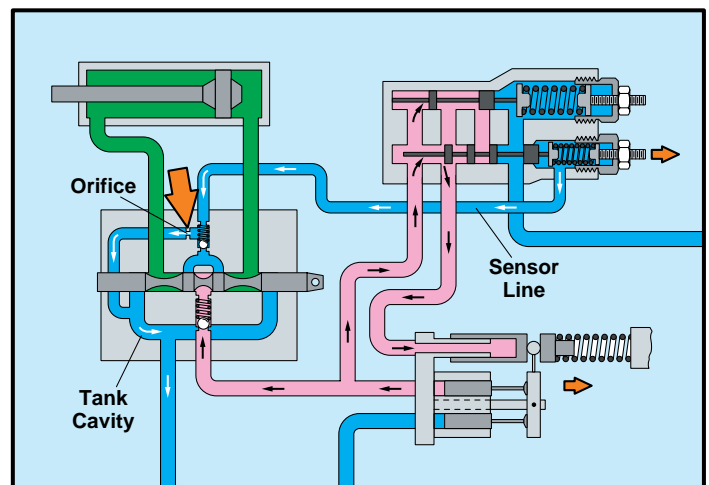

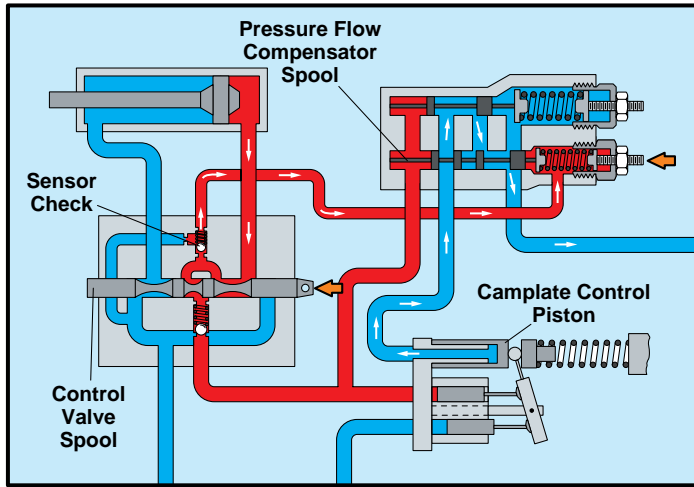

Now, let's see what happens when the directional control valve spool is moved to the left. The first thing to note is that pressure contained in the cylinder is channeled by the valve spool, around the sensor check, to the spring chamber at the right of the pressure-flow compensator spool. This pressure combines with the force of the 200 PSI spring to move the pressure-flow compensator spool to the left and drains some of the pressure from the camplate control piston to tank. The spring forces the camplate control piston to move the camplate to a greater angle and the pump begins to produce more flow.

Because the spool in the directional control valve was moved, pump flow can now pass around the lift check, past the spool, and into the base of the cylinder. The orifice in the directional control valve is so small that there is no significant pressure loss in the line that leads to the right end of the pressure-flow compensator spool.

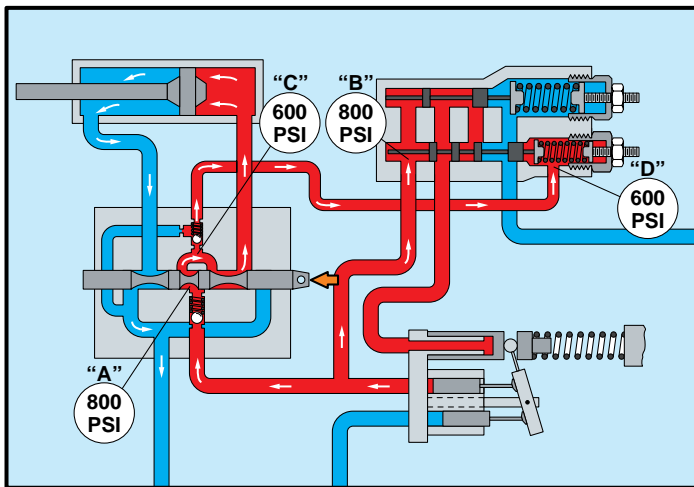
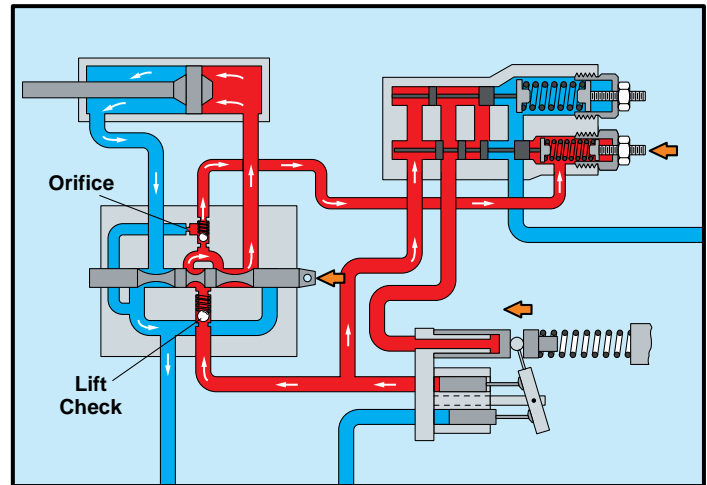

By installing some gauges, we can see how the pressure drop across the lands of the directional control valve spool can be used to control pump flow. Gauges "A" and "B" have the same pressure and gauges "C" and "D" have the same pressure. Notice that there is exactly 200 PSI difference in the readings of the two sets of gauges. The pressure drop across the lands of the spool in conjunction with the pressure-flow compensator spool and 200 PSI spring control pump flow. Notice that 800 PSI on the left end of the spool is opposed by 600 PSI of oil pressure and 200 PSI of spring pressure. 600 and 200 is 800 PSI.

In this diagram, the spool in the directional control valve has been moved farther in the same direction. Because it has moved farther, the passage around the spool is larger; which means that it creates less resistance to oil flow. This lessening of resistance is felt by the pressure-flow compensator spool. The pressure-flow compensator spool moves to drain more oil from the camplate control piston which allows the pump to stroke to a greater displacement angle. The pump produces more flow.

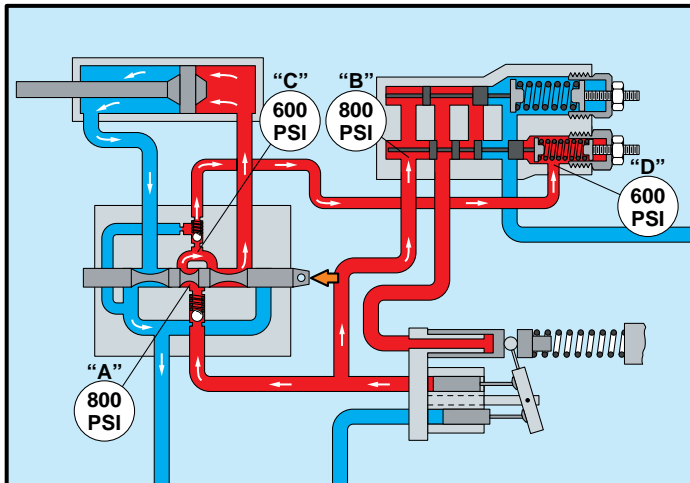
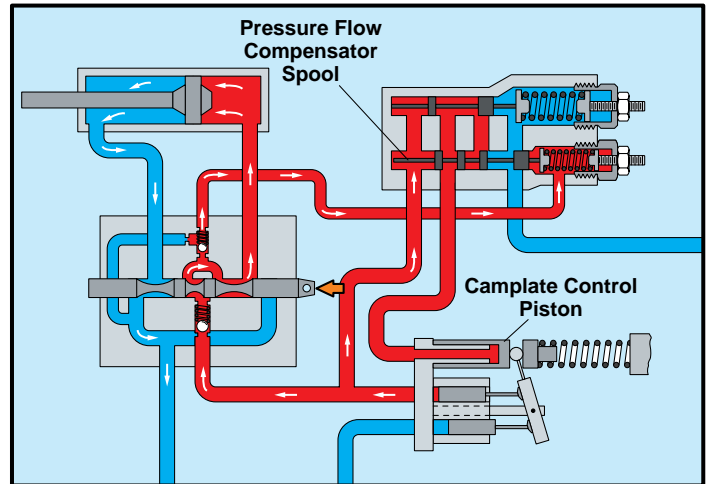

If we install those four gauges again we see that, even though the resistance created by the spool passage is less and the pump is producing more flow, there is still exactly 200 PSI difference in pressure between the two sets of gauges. The pressure-flow compensator spool will always strive to maintain this 200 PSI difference while the spool in the directional control valve is moved to direct oil to an actuator.

This creates a very efficient hydraulic system because the pump will provide only the oil required at 200 PSI above actual system working pressure.

**Provides the oil required at
200 PSI above system working
pressure.**

Automatically adjusts to the varying pressure and flow demands.

The pump will automatically adjust itself to the varying pressure and flow demands of the system.

Eventually, the piston in the cylinder reaches the end of its travel. When it does, flow past the lands of the directional control spool stops. Pressure equalizes on both sides of the directional control spool and pressure also equalizes on both ends of the pressure-flow compensator spool. The 200 PSI spring forces the pressure flow compensator spool all the way to the left. When pressure reaches 3000 PSI, the high pressure compensator spool moves to the right and directs oil to the camplate control piston. The piston moves the camplate to near zero angle and the pump stops producing flow. This is called the high pressure standby mode.

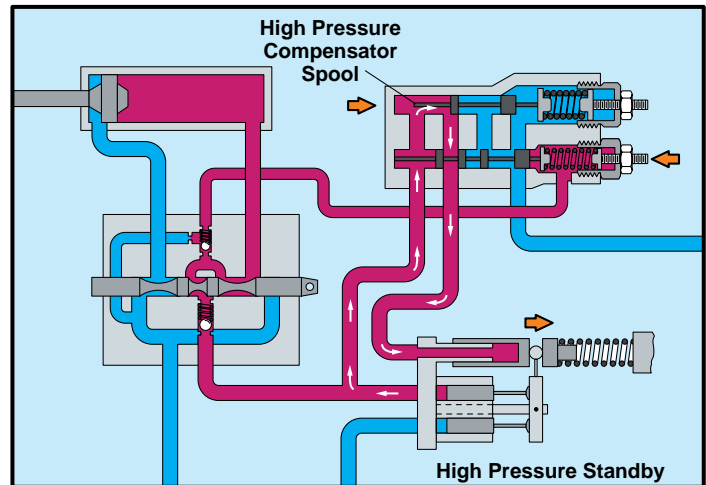

Remains in high pressure standby until the load is overcome or the valve spool is returned to neutral.

The Eaton pump will remain in high pressure standby until (1) The load is overcome or (2) The valve spool is returned to neutral.

It will produce only enough flow to make up for internal leakage.

Produces only enough flow to make up for internal leakage.

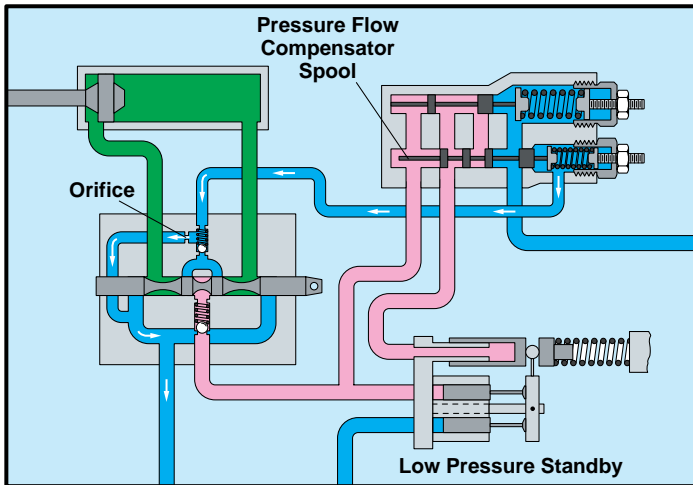

Here the spool in the directional control valve has been returned to neutral. The pressure that was directed to the right end of the pressure-flow compensator spool is now drained through the orifice in the control valve. The pump will stroke back to near zero displacement and practically no flow is produced. The 200 PSI acting on the left end of the pressure-flow compensator spool will be offset by the 200 PSI spring acting on the right end of the spool. The spool will modulate back and forth to maintain 200 PSI in the discharge circuit of the pump.

Advantages of Load Sensing

Advantages of the Eaton Pressure-Flow Load Sensing System

Now that you understand the operation of the Eaton pressure-flow load sensing system, let's discuss its advantages as compared to a conventional, open center, fixed displacement system.

The Eaton system uses horsepower more efficiently than other systems. More efficient use of horsepower means better fuel economy and less heat generated in the system.

Uses horsepower more efficiently

- Better fuel economy
- Less system heat

Why does it use horsepower more efficiently?

Why does the Eaton system use horsepower more efficiently?

Hydraulic Energy

$$Hp = \frac{PSI \times GPM}{1714}$$

A commonly used engineering formula states, the horsepower required to drive a hydraulic pump is equal to system pressure (PSI), times system flow (GPM), divided by a constant of 1714. The formula is accurate but does not take into consideration mechanical losses due to friction.

Let's see how the formula works. Consider a typical system that is producing a flow of 20 GPM at a pressure of 2000 PSI. 2000 PSI times 20 GPM, divided by the constant 1714 tells us that 23.3 horsepower is required to drive the pump under the stated conditions. If you look at the formula carefully, you can see that if either pressure or flow changes, the horsepower required to drive the pump also changes.

System flow = 20 GPM
System Pressure = 2000 PSI

$$\frac{2000 \text{ PSI} \times 20 \text{ GPM}}{1714} = 23.3 \text{ Hp}$$

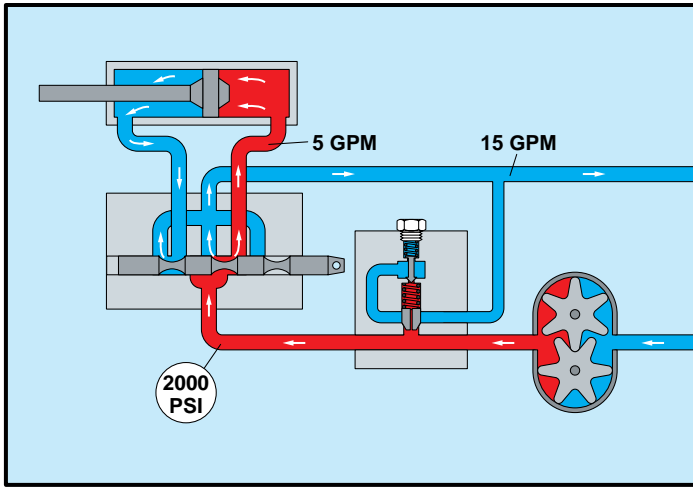

Here is a typical open center, fixed displacement hydraulic system. The pump can produce 20 GPM. Suppose the operator wants to meter oil to the cylinder that requires 2000 PSI to move the load. If only 5 of the 20 GPM are required to move the cylinder at the desired rate, 15 GPM are returned to tank. However, the full 20 GPM is pressurized to 2000 PSI.

The formula tells us that only 5.8 horsepower is used to move the load.

Oil to load is useful work.

$$\frac{2000 \text{ PSI} \times 5 \text{ GPM}}{1714} = 5.8 \text{ Hp}$$

Oil to tank is wasted horsepower

$$\frac{2000 \text{ PSI} \times 15 \text{ GPM}}{1714} = 17.5 \text{ Hp}$$

17.5 horsepower is wasted in returning oil to the tank.

Another engineering equation states that one horsepower minute is equal to 42.4 BTU's of heat per minute. Each horsepower minute that is not converted into mechanical work is converted into heat.

**1 Hp/min. = 42.4 BTU/min.
Each horsepower minute
that is not converted into
mechanical work, is
converted into heat.**

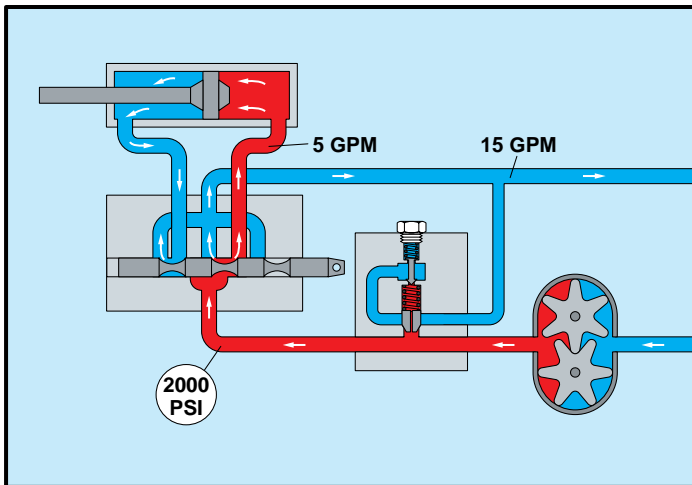

That means, in this system, 17.5 horsepower times 42.4 BTU's or 742 BTU's of heat per minute must be absorbed by the hydraulic system and, eventually, dissipated through an oil cooler.

In the Eaton system, 5 GPM is metered to the cylinder and the pump self adjusts to pump only the 5 GPM required at 2000 PSI plus the 200 PSI to actuate the compensator.

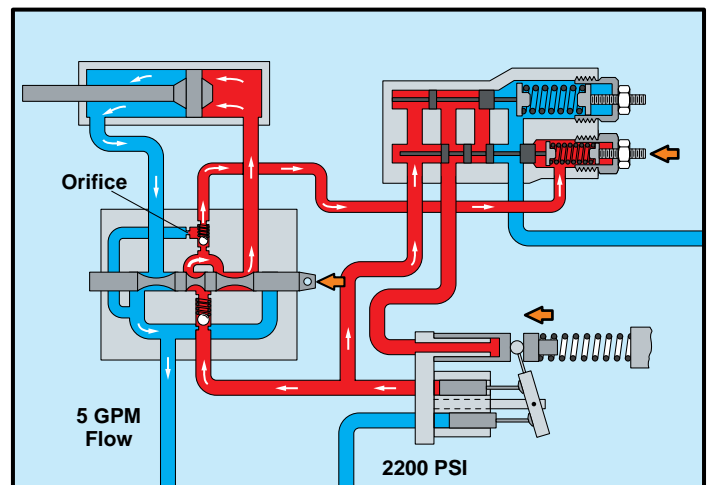

$$\frac{2000 \text{ PSI} \times 5 \text{ GPM}}{1714} = 5.8 \text{ Hp}$$

Only 5 GPM is pressurized to 2200 PSI so only 6.4 horsepower is required to do the work.

That is a savings of 16.9 horsepower or 716 BTU's of heat per minute or 42,960 BTU's per hour.

**Eaton saves
16.9 Hp or 716 BTU per min.
or 42,960 BTU per hour saved.**

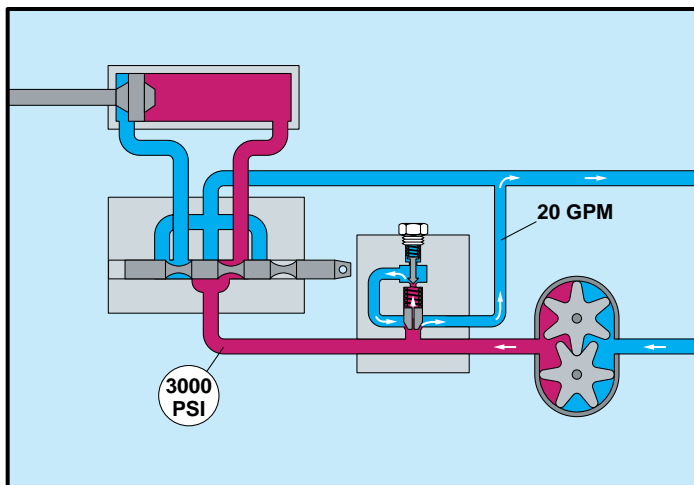

Here is the conventional system again, but this time it is shown in the relief position. The piston in the cylinder has reached the end of its travel and all pump flow is passing through the system relief valve that is set at 3000 PSI.

3000 PSI times 20 GPM divided by 1714 shows that 35 horsepower is wasted in by-passing oil through the system relief valve.

$$\frac{3000 \text{ PSI} \times 20 \text{ GPM}}{1714} = 35 \text{ Hp}$$

$$35 \text{ Hp} \times 42.4 \text{ BTU} = 1484 \text{ per min.} \\ \text{or } 89,040 \text{ BTU per hour}$$

35 horsepower times 42.4 BTU's per minute equals 1484 BTU's of heat that is generated unnecessarily every minute or 89,040 BTU's per hour.

In the Eaton system, when the piston in the cylinder reaches the end of its travel, the pump goes into high pressure standby. The pump camplate moves to the neutral position and no flow is produced.

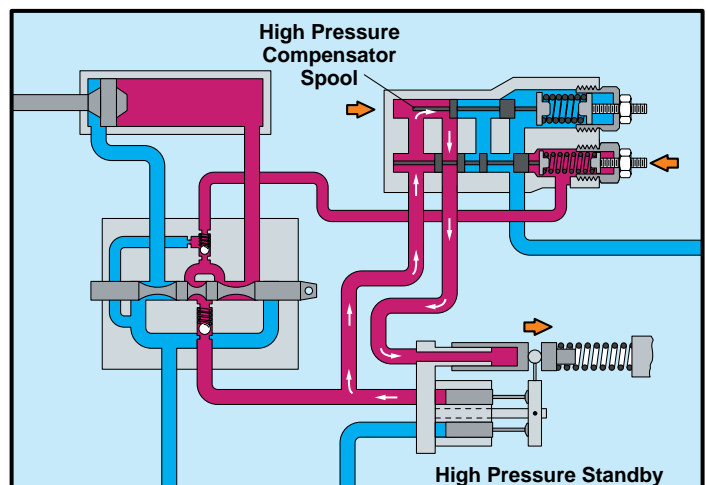

Only 4.7 horsepower is wasted

**Only 199 BTU's per minute
wasted or 11,940 per hour**

Since there is a maximum of only 2.7 GPM internal leakage at 3000 PSI, only 4.7 horsepower is wasted. 4.7 times 42.4 BTU's per minute equals only 199 BTU's of heat that is generated unnecessarily every minute or only 11,940 BTU's per hour. This compares to 89,040 BTU's in the open center system.

In addition to using horsepower more efficiently, the Eaton pressure-flow and load sensing system gives the operator better control.

- 1. Uses horsepower more efficiently**
- 2. Better operator control**

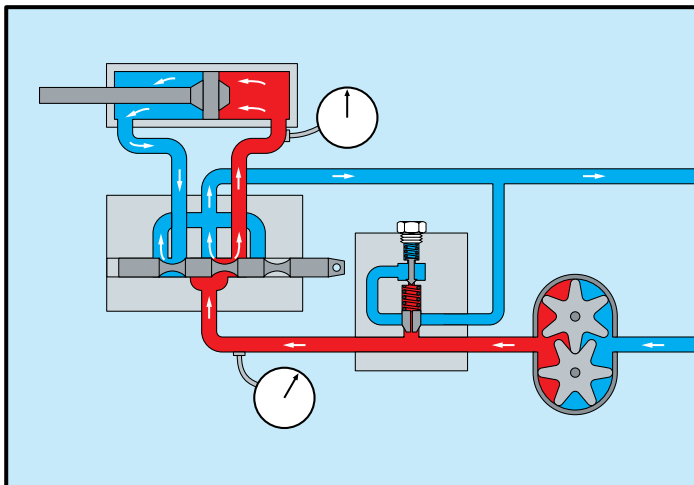

Here is why. Suppose that in this conventional system the pump is producing 20 GPM and the valve spool is moved to direct part of pump flow to the cylinder and part to tank. The flow of oil past the control spool causes a certain pressure drop. That pressure drop can be felt by the operator in the effort required to move the valve spool control lever.

If the spool is moved to direct more or less oil to the cylinder, the pressure drop across the valve spool will change and the control lever effort will be different. The operator must become accustomed to the ever-changing "feel" of the lever.

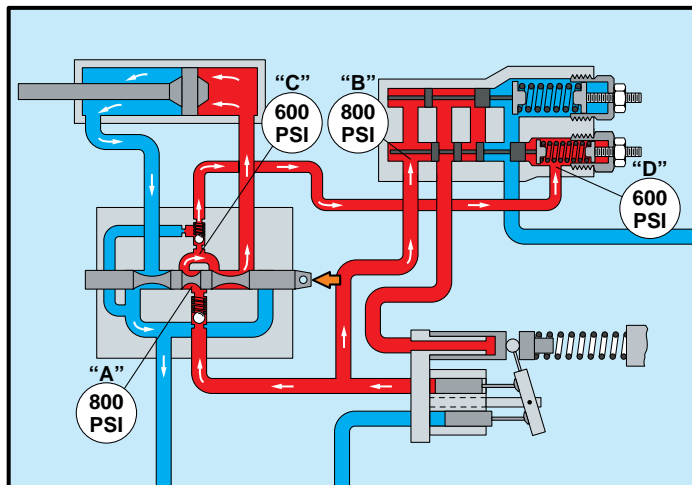
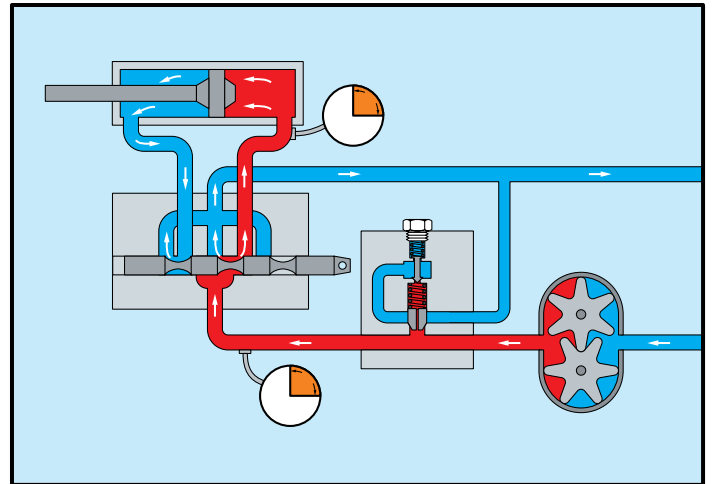

In the Eaton system it doesn't make any difference how far the control valve spool is moved. The compensator will always adjust pump flow so that there is exactly a 200 PSI pressure drop across the spool.

It is much easier for the operator to control the operations of the system because the lever always has the same "feel".

The lever always has the same "feel"

- 1. Uses horsepower more efficiently**
- 2. Better control**
- 3. One pump meets the pressure and flow requirements for several circuits**

Another distinct advantage of the Eaton system is that one pump meets the pressure and flow requirements for several circuits.

In the open center, fixed displacement system, a separate pump is required for each circuit that requires a different flow rate or a flow divider must be used.

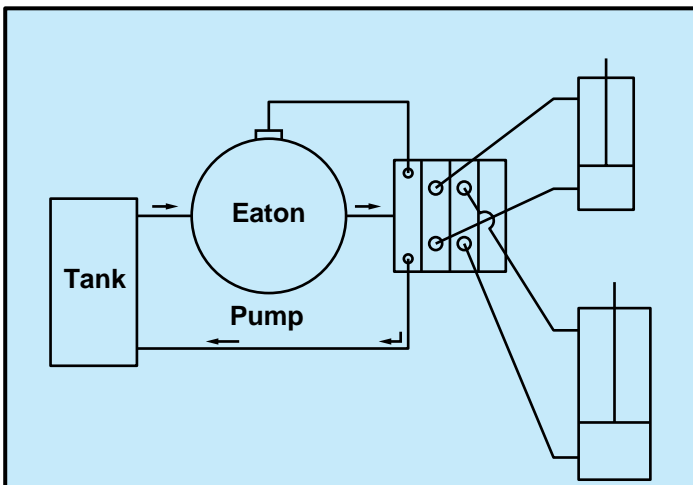
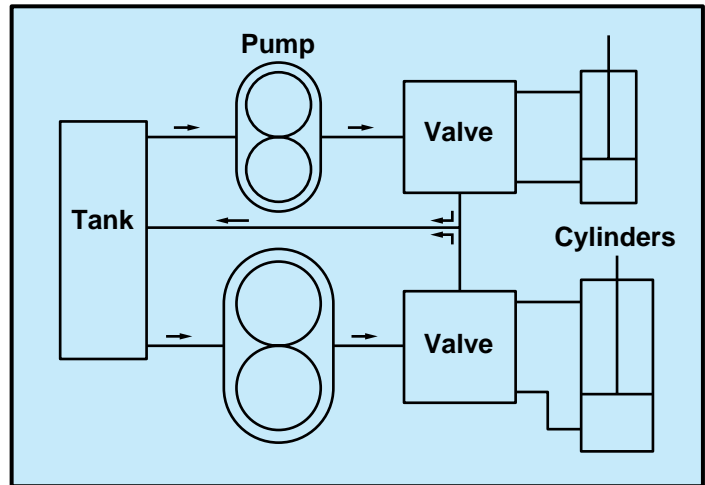

In the Eaton system the pump adjusts itself to the flow requirements of each circuit.

The Eaton system also has the ability to use one pump for multiple cylinder actuation. All cylinders will move at the same rate, regardless of load, with the use of flow compensation in each circuit.

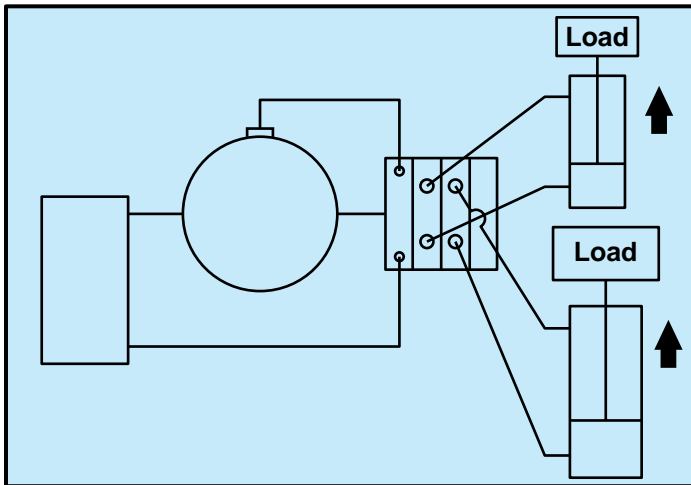
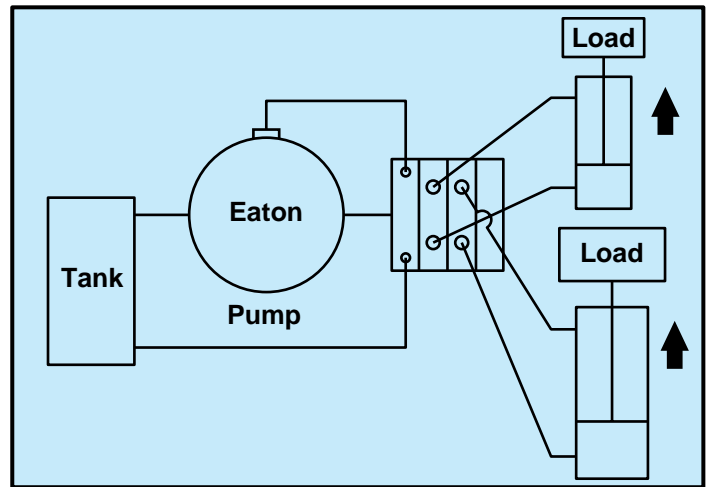

In the conventional system, the actuator with the least load will move first, then the other.

When you understand the principles of operation of the Eaton pressure-flow and load sensing system, it's easy to see that it's the best on the market because; it uses horsepower efficiently,

1. Uses horsepower more efficiently

- 1. Uses horsepower more efficiently**
- 2. Better control**

it provides better control,

and permits the use of one pump for multiple circuit operation where different flows and different pressures are required.

- 1. Uses horsepower more efficiently**
- 2. Better control**
- 3. One pump meets the pressure and flow requirements for several circuits**

**Eaton
Hydraulics
Division**

Development and Testing

Many hours were devoted to the development and testing process of the load sensing pump.

The rotating group and camplate had already been developed and tested for a line of propulsion pumps so they were used as the test bed for the load sensing pump. What had to be done was to perfect the compensator and the camplate control piston.

Many millions of test cycles were run on the test pumps. Test stands ran around the clock, testing and retesting. The main obstacle to overcome during the development of the load sensing pump was camplate stability in relation to response and recovery times. If the response was too quick, the pump was unstable, if the response was too slow, high pressure spikes or pressure overshoots were seen in the system. It took many hours of testing to get just the right combination to give the right response and a stable responding pump.

After the correct operating characteristics were designed into the pump, then it was necessary to start the long task of endurance testing the pump and

compensator. The endurance cycle consisted of running the pump at rated speed, full displacement and 75% pressure for 1/2 second. The pump was then deadheaded to zero flow (zero displacement) at full pressure for 1/2 second. This alternating cycle was continued for 500,000 cycles then the pumps were checked for operating efficiency. The pumps were then torn down and inspected for signs of deterioration. It takes 138.9 hours to complete each 500,000 cycle test. These tests were continued until our engineers felt the design of the pump was solid.

The next phase of the testing program was the "cycle to destruction" test. The pumps were again cycled and run until there was a loss of 10% flow or a mechanical failure. This helped to determine the long term durability of the pump design. At this point, there were also pumps on test in customer labs being run at their test perimeters.

The end result of all this testing was that when the load sensing pump was released for production. It is a very solid, durable design, ready for application on a variety of machines.

Comparison of Systems

After the load sensing pump was thoroughly developed, it was now time to install it on an actual machine application. The backhoe was selected because it utilizes a very hard working hydraulic system with lots of variables.

Eaton purchased and leased several different types of backhoes in order to get a thorough evaluation of the comparison test.

The backhoe purchased was a high pressure compensated, closed center type backhoe. The conversion consisted of installing a load sensing piston pump, a load sensing control valve and removal of the heat exchanger. The pressure lines to and from the cylinders were also replaced with the next size larger lines to reduce line loss.

The leased backhoes were used as stock from the factory. One was a high pressure, closed center type, the other had an open center system.

There are basically two ways of measuring the efficiency of a backhoe system. One is by comparing fuel consumption while doing productive work and the other is to measure the amount of heat generated during the tests.

The following graphs show the results of these tests:

Fuel Consumption 1-1/2 Hour Test

Closed Center System	5143 ml per 1/2 hr = 2.70 gallons per hr
Open Center System	4508 ml per 1/2 hr = 2.38 gallons per hr
Load Sensing System	3380 ml per 1/2 hr = 1.78 gallons per hr

Fuel Consumption per Yardage Moved

Machine No. 1

Closed center machine with 1100 hours	
2 hour run	
Average fuel consumed per hour	1.64 gal.
Average cu. yd. dirt moved per hour	31.75 cu. yds.
Gallons fuel consumed per cu. yd.	.05165 gal.

Machine No. 2

Open center machine with 2680 hours	
2 hour run	
Average fuel consumed per hour	1.81 gal.
Average cu. yd. dirt moved per hour	42.25 cu. yds.
Gallons fuel consumed per cu. yd.	.04284 gal.

Machine No. 3

Load sensing machine with 50 hours	
2 hour run	
Average fuel consumed per hour	2.12 gal.
Average cu. yd. dirt moved per hour	64.5 cu. yds.
Gallons fuel consumed per cu. yd.	.03286 gal.

Improved efficiency over machine No. 1 36.4%

Improved efficiency over machine No. 2 23.3%

Heat Test Results

Closed center with oil cooler	106° F over ambient
Load sensing system without cooler	116° F over ambient
Open center system with oil cooler	98° F over ambient
Load sensing system without cooler	74° F over ambient

Applications

Load sensing is an ideal hydraulic system when the system you desire requires one or more of the following characteristics:

- One system pump to operate multiple circuits with variable pressures and flow
- System that requires variable flow rates
- System that will standby at low pressure and low flow until pressure or flow is required
- System that requires a constant flow rate regardless of input RPM and variable pressure requirements
- System that does not waste excessive energy and create excessive system heat
- System that drives hydraulic motor(s) at constant speed regardless of load
- System that reaches peak pressure frequently

Load sensing has been used on many of the following machine applications:

- | | |
|------------------------------|----------------------------|
| Backhoes | Combines |
| Front end loaders | Assist drive axles |
| Agricultural tractor systems | Cable tension reels |
| Man lifts | Truck mounted augers |
| Scissor lifts | Cable winches |
| Cranes | Marine generator drives |
| Garbage compaction trucks | Machine tool systems |
| Concrete trucks | Log splitters |
| Dump bed trucks | Presses |
| Salt spreader trucks | Shears |
| Propulsion ground drives | Vehicle suspension systems |

As you can see, the load sensing system can be used on virtually any type hydraulic system. The system advantages that it has far exceeds those off the open center and high pressure closed center systems. What can it do for your system?

Future of Load Sensing Systems

Load sensing is the system of the future, and it is here today! The efficient characteristics of load sensing make it the most desirable system of all. For sophisticated systems, it can be coupled with electronic controls and it will provide the precise hydraulic power required.

We see the future of load sensing as supplying the variable power demands of very sophisticated electronically controlled hydraulic systems. Sensors of all types will feed information into microprocessors, the microprocessor will direct electric current to proportional solenoid control valves, they in turn will direct the pressure and flow of the load sensing pump in the exact proportion to the proper actuator.

Load Sensing - The Ultimate Hydraulic System!

Information contained in this catalog is accurate as of the publication date and is subject to change without notice. Performance values are typical values. Customers are responsible for selecting products for their applications using normal engineering methods.

Eaton Corporation
Hydraulics Division
15151 Hwy. 5
Eden Prairie, MN 55344
Telephone: 612/937-7254
Fax: 612/937-7130

Sumitomo Eaton
Hydraulic Company Ltd.
Ooi-Cho Kameoka-Shi
621-0017 Kyoto
Japan
Telephone: [+81] 771-22-9601
Fax: [+81] 771-29-2020

Eaton Ltd.
Hydraulics Division
Glenrothes, Fife
Scotland, KY7 4NW
Telephone: [+44] (0)1592-771-771
Fax: [+44] (0)1592-773-184

Eaton Ltd.
7th Floor, Woo Duk Building
832-2 Yeoksam-Dong, Kangnam-Ku
Soeul 135-750
Korea
Telephone: [+82] 2-557-0595
Fax: [+82] 2-557-1634

Eaton B.V.
Boeing Avenue 11
1119 PC Schiphol-Rijk
The Netherlands
Telephone: [+31] (0)20-655 6700
Fax: [+31] (0)20-655 6800

Eaton Hydraulics (Shanghai) Co. Ltd.
388 Aidu Road, Waigaogiao FTZ
Pudong New Area
Shanghai 200137
Peoples Republic of China
Telephone: [+86] 21-5046 0758
Fax: [+86] 21-5046 0767

Sumitomo Eaton Hydraulic Co.
5 Temasek Blvd.
42-01 Suntec Tower Three
Singapore 03988
Telephone: [+65] 832-7727
Fax: [+65] 832-7733

Jining Eaton Hydraulic Co. Ltd.
6 Ji Da Road
Jining City
Shandong Province 272131
Peoples Republic of China
Telephone: [+86] 537-2221288
Fax: [+86] 537-2221557



Quality System Certified
Products in this catalog are manufactured
in an ISO-9001-certified site.